

## 平焊法兰GOST-33259-2015(PL) SLIP-ON WELDING FLANGE

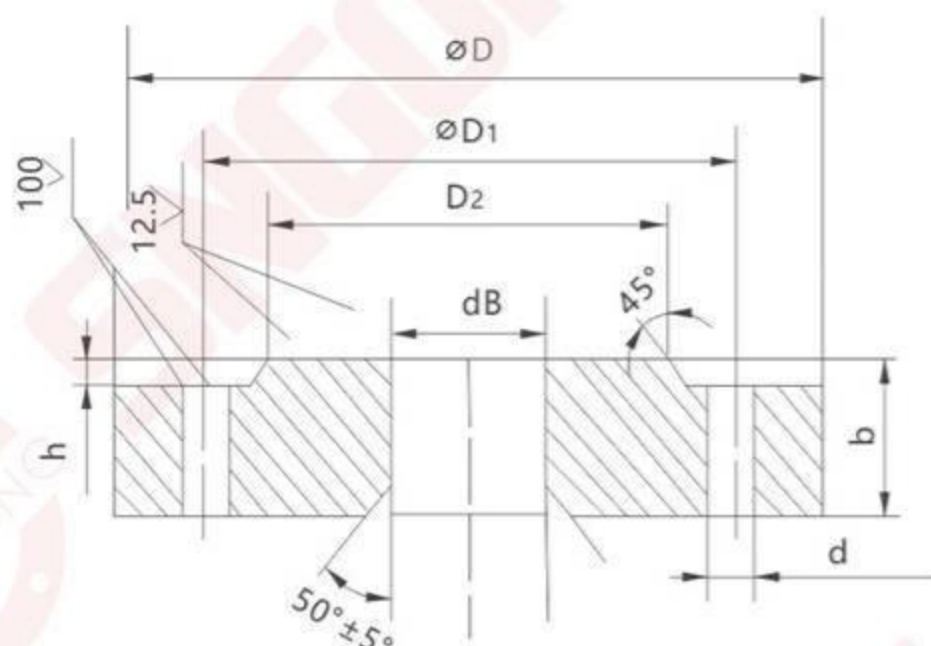

PN6 GOST 33259-2015 Type 01 Char.B

(mm)

DN	dB	D	D1	D2	h	b	d	No of holes	Weight kg
10	15	75	50	35	2	12	11	4	0.31
15	19	80	55	40	2	12	11	4	0.33
20	26	90	65	50	2	14	11	4	0.53
25	33	100	75	60	2	14	11	4	0.64
32	39	120	90	70	2	15	14	4	1.01
40	46	130	100	80	3	16	14	4	1.21
50	59	140	110	90	3	16	14	4	1.33
65	78	160	130	100	3	16	14	4	1.63
80	91	185	150	128	3	18	18	4	2.44
100	110	205	170	148	3	18	18	4	2.85
125	135	235	200	178	3	20	18	8	3.88
150	161	260	225	202	3	20	18	8	4.39
200	222	315	280	258	3	22	18	8	5.89
250	273	370	335	312	3	23	18	12	7.67
300	325	435	395	365	4	24	22	12	10.28
350	377	485	445	415	4	26	22	12	12.58
400	426	535	495	465	4	28	22	16	15.2
450	480	590	550	520	4	28	22	16	17.25
500	530	640	600	570	4	29	22	16	19.72
600	630	755	705	670	5	30	26	20	26.24
700	720	860	810	775	5	32	26	24	36.68
800	820	975	920	880	5	32	30	24	46.14



**PN10** GOST 33259-2015 Type 01 Char.B

(mm)

DN	dB	D	D1	D2	h	b	d	No of holes	Weight kg
10	15	90	60	42	2	12	14	4	0.46
15	19	95	65	47	2	12	14	4	0.51
20	26	105	75	58	2	14	14	4	0.74
25	33	115	85	68	2	14	14	4	0.89
32	39	135	100	78	2	16	18	4	1.4
40	46	145	110	88	3	18	18	4	1.71
50	59	160	125	102	3	18	18	4	2.06
65	78	180	145	122	3	20	18	4	2.8
80	91	195	160	133	3	20	18	4	3.19
100	110	215	180	158	3	22	18	8	3.96
125	135	245	210	184	3	24	18	8	5.4
150	161	280	240	212	3	24	22	8	6.62
200	222	335	295	268	3	24	22	8	8.05
250	273	390	350	320	3	26	22	12	10.65
300	325	440	400	370	4	28	22	12	12.9
350	377	500	460	430	4	28	22	16	15.85
400	426	565	515	482	4	30	26	16	21.56
500	530	670	620	585	4	32	26	20	27.7
600	630	780	725	685	5	36	30	24	39.4
700	720	895	840	800	5	39	30	24	59.46
800	820	1010	950	905	5	42	33	24	79.16
900	920	1110	1050	1005	5	45	33	28	94.13
1000	1020	1220	1160	1110	5	48	33	28	118.43
1200	1222	1455	1380	1330	5	56	39	32	197.44
1400	1420	1675	1590	1530	5	65	45	36	278.92
1600	1620	1915	1820	1750	5	75	52	40	422.65

**PN16** GOST 33259-2015 Type 01 Char.B

(mm)

DN	dB	D	D1	D2	h	b	d	No of holes	Weight kg
10	15	90	60	42	2	14	14	4	0.54
15	19	95	65	47	2	14	14	4	0.61
20	26	105	75	58	2	16	14	4	0.86
25	33	115	85	68	2	18	14	4	1.17
32	39	135	100	78	2	18	18	4	1.58
40	46	145	110	88	3	20	18	4	1.96
50	59	160	125	102	3	22	18	4	2.58
65	78	180	145	122	3	24	18	4	3.42
80	91	195	160	133	3	24	18	4	3.71
100	110	215	180	158	3	26	18	8	4.73
125	135	245	210	184	3	28	18	8	6.38
150	161	280	240	212	3	28	22	8	7.81
200	222	335	295	268	3	30	22	12	10.1
250	273	405	355	320	3	31	26	12	14.49
300	325	460	410	370	4	32	26	12	17.78
350	377	520	470	430	4	34	26	16	22.88
400	426	580	525	482	4	38	30	16	31
500	530	710	650	585	4	48	33	20	57.01
600	630	840	770	685	5	50	39	20	80.03
700	720	910	840	800	5	52	39	24	84.21
800	820	1020	950	905	5	54	39	24	104.41
900	920	1120	1050	1005	5	59	39	28	128.6
1000	1020	1255	1170	1110	5	63	45	28	179.37
1200	1220	1485	1380	1330	5	76	52	32	297.78

PN25 GOST 33259-2015 Type 01 Char.B

(mm)

DN	dB	D	D1	D2	h	b	d	No of holes	Weight kg
10	15	90	60	42	2	16	14	4	0.63
15	19	95	65	47	2	16	14	4	0.7
20	26	105	75	58	2	18	14	4	0.98
25	33	115	85	68	2	18	14	4	1.17
32	39	135	100	78	2	20	18	4	1.77
40	46	145	110	88	3	22	18	4	2.18
50	59	160	125	102	3	24	18	4	2.71
65	78	180	145	122	3	24	18	8	3.22
80	91	195	160	133	3	26	18	8	4.06
100	110	230	190	158	3	28	22	8	5.92
125	135	270	220	184	3	30	26	8	8.26
150	161	300	250	212	3	30	26	8	10.12
200	222	360	310	278	3	32	26	12	13.34
250	273	425	370	335	3	34	30	12	18.9
300	325	485	430	390	4	36	30	16	23.95
350	377	550	490	450	4	42	33	16	34.35
400	426	610	550	505	4	44	33	16	44.62
500	530	730	660	615	4	52	39	20	67.3
600	630	840	770	720	5	54	39	20	90.87
700	720	960	875	820	5	60	45	24	126.82
800	820	1075	990	930	5	68	45	24	181.43



## 对焊法兰GOST-33259-2015(WN) WELDING NECK FLANGE

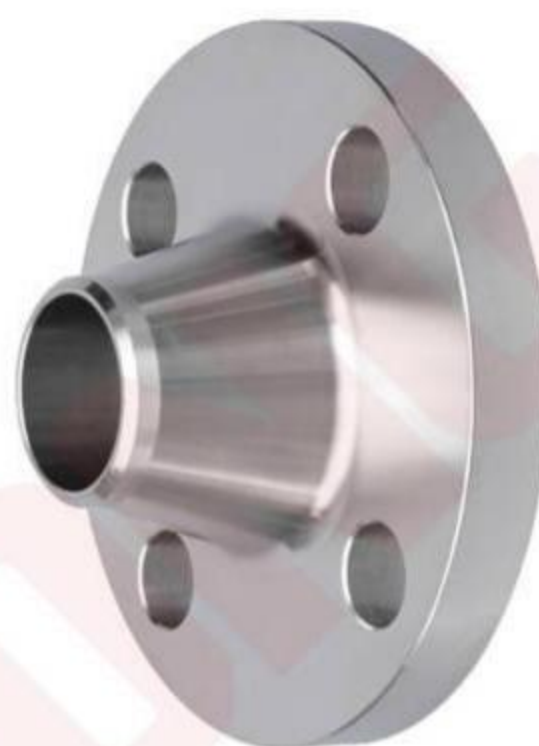
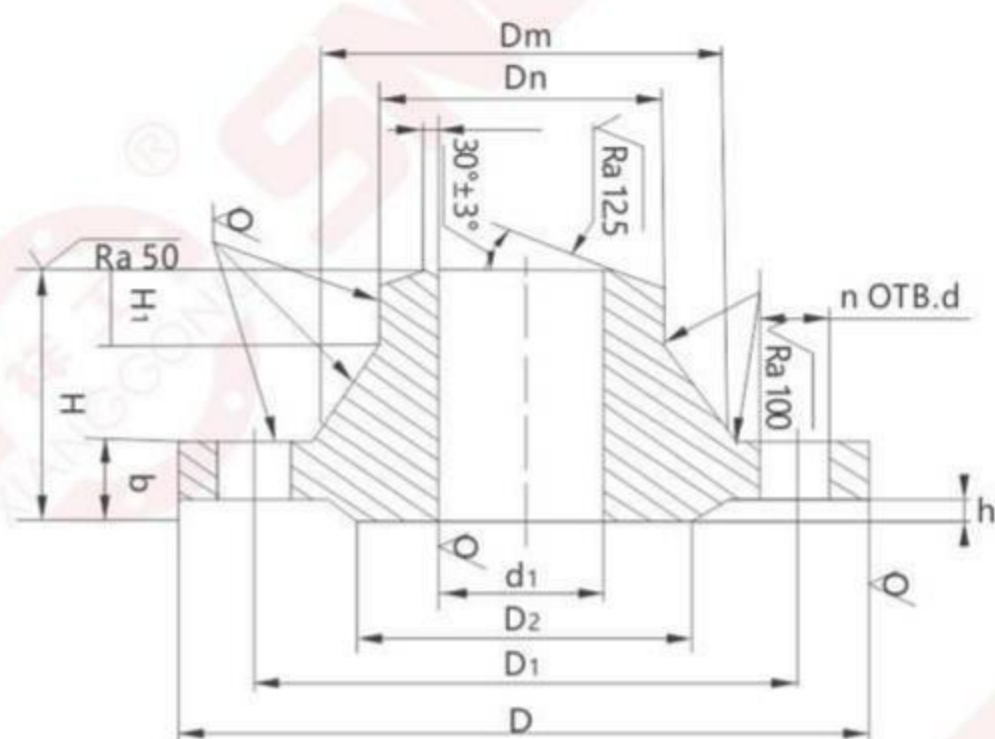

PN0.6 GOST 33259-2015 Type 01 Char.B

(mm)

DN	外径	孔距	密封面	大径	小径	内孔	厚度	h	总高	颈口高	孔径	孔数	理重
	D	D1	D2	Dm	Dn	d1	b		H	H1			
10	75	50	35	22	15	8	12	2	29	6	11	4	0.34
15	80	55	40	28	19	12	12	2	30	6	11	4	0.40
20	90	65	50	36	26	18	12	2	32	6	11	4	0.53
25	100	75	60	42	33	25	14	2	32	6	11	4	0.76
32	120	90	70	50	39	31	14	2	35	6	14	4	1.10
40	130	100	80	60	46	38	15	3	38	7	14	4	1.36
50	140	110	90	70	58	49	15	3	38	8	14	4	1.53
65	160	130	110	88	77	66	15	3	38	9	14	4	1.97
80	185	150	128	102	90	78	16	3	40	10	18	4	2.76
100	205	170	148	122	110	96	16	3	41	10	18	4	3.35
125	235	200	178	148	135	121	18	3	43	10	18	8	4.66
150	260	225	202	172	161	146	18	3	46	12	18	8	5.37
200	315	280	258	235	222	202	20	3	53	15	18	8	8.37
250	370	335	312	288	278	254	21	3	53	15	18	12	10.99
300	435	395	365	340	330	303	22	4	54	15	18	12	14.82
350	485	445	415	390	382	351	22	4	54	15	22	12	17.69
400	535	495	465	440	382	332	22	4	54	15	22	16	20.55
450	590	550	520	494	484	450	22	4	54	15	22	16	23.60
500	640	600	570	545	535	501	23	4	54	15	22	16	26.63
600	755	705	670	650	636	602	24	5	60	16	26	20	35.79
700	860	810	775	740	726	692	24	5	60	16	26	24	44.31
800	975	920	880	844	826	792	24	5	65	16	30	24	56.17
900	1075	1020	980	944	926	892	26	5	65	16	30	24	66.80
1000	1175	1120	1080	1044	1028	992	26	5	65	16	30	28	73.51
1200	1400	1340	1295	1248	1228	1192	28	5	75	20	33	32	111.43
1400	1620	1560	1510	1456	1428	1392	32	5	90	20	33	36	156.58
1600	1820	1760	1710	1660	1628	1592	37	5	100	20	33	40	218.57



**PN1.0** GOST 33259-2015 Type 01 Char.B

(mm)

DN	外径	孔距	密封面	大径	小径	内孔	厚度	h	总高	颈口高	孔径	孔数	理重
	D	D1	D2	Dm	Dn	d1	b		H	H1			
10	90	60	42	25	15	8	12	2	35	6	14	4	0.50
15	95	65	47	30	19	12	12	2	35	6	14	4	0.58
20	105	75	58	38	26	18	14	2	38	6	14	4	0.87
25	115	85	68	45	33	25	14	2	40	6	14	4	1.05
32	135	100	78	55	39	31	15	2	42	6	18	4	1.54
40	145	110	88	62	46	38	16	3	45	7	18	4	1.83
50	160	125	102	76	58	49	16	3	45	8	18	4	2.26
65	180	145	122	94	77	66	18	3	48	10	18	4	3.17
80	195	160	133	105	90	78	18	3	50	10	18	4	3.67
100	215	180	158	128	110	96	20	3	51	12	18	8	4.70
125	245	210	184	156	135	121	22	3	60	12	18	8	6.71
150	280	240	212	180	161	146	22	3	60	12	22	8	8.17
200	335	295	268	240	222	202	22	3	61	16	22	8	11.35
250	390	350	320	290	278	254	24	3	63	16	22	12	14.64
300	440	400	370	345	330	303	26	4	64	16	22	12	18.66
350	500	460	430	400	382	351	26	4	64	16	22	16	24.00
400	565	515	482	445	382	398	26	4	64	16	26	16	30.00
450	615	565	532	500	484	450	26	4	69	16	26	20	34.70
500	670	620	585	550	535	501	28	4	69	16	26	20	39.20
600	780	725	685	650	636	602	29	5	70	18	30	20	48.80
700	895	840	800	744	726	692	30	5	70	18	30	24	65.26
800	1010	950	905	850	826	792	32	5	80	18	33	24	87.24
900	1110	1050	1005	950	926	892	34	5	85	20	33	28	103.02
1000	1220	1160	1110	1050	1028	992	34	5	85	20	33	28	119.19
1200	1455	1380	1330	1256	1228	1192	38	5	95	25	39	32	179.91

**PN1.6** GOST 33259-2015 Type 01 Char.B

(mm)

DN	外径	孔距	密封面	大径	小径	内孔	厚度	h	总高	颈口高	孔径	孔数	理重
	D	D1	D2	Dm	Dn	d1	b		H	H1			
10	90	60	42	26	15	8	14	2	35	6	14	4	0.59
15	95	65	47	30	19	12	14	2	35	6	14	4	0.68
20	105	75	58	38	26	18	14	2	38	6	14	4	0.87
25	115	85	68	45	33	25	14	2	40	6	14	4	1.05
32	135	100	78	55	39	31	15	2	42	6	18	4	1.54
40	145	110	88	64	46	38	16	3	45	7	18	4	1.85
50	160	125	102	76	58	49	16	3	48	8	18	4	2.28
65	180	145	122	94	77	66	18	3	50	10	18	4	3.19
80	195	160	133	110	90	78	20	3	53	10	18	4	4.21
100	215	180	158	130	110	96	20	3	53	12	18	8	4.90
125	245	210	184	156	135	121	22	3	60	12	18	8	6.75
150	280	240	212	180	161	146	22	3	60	12	22	8	8.30
200	335	295	268	240	222	202	24	3	61	16	22	12	11.79
250	405	355	320	292	278	254	26	3	68	16	26	12	17.36
300	460	410	370	346	330	303	28	4	70	16	26	12	22.76
350	520	470	430	400	382	351	32	4	74	16	26	16	32.04
400	580	525	482	450	432	398	36	4	79	16	30	16	43.00
450	640	585	532	506	484	450	38	4	89	16	30	20	54.00
500	710	650	585	559	535	501	42	4	94	16	33	20	70.97
600	840	770	685	660	636	602	46	5	95	18	39	20	99.30
700	910	840	800	750	726	692	48	5	100	18	39	24	105.90
800	1020	950	905	850	826	792	50	5	100	20	39	24	130.57
900	1120	1050	1005	958	926	892	52	5	115	20	39	28	157.83
1000	1255	1170	1110	1060	1028	992	54	5	115	22	45	28	203.39
1200	1485	1390	1330	1268	1228	1192	56	5	130	30	52	32	284.94



**PN2.5** GOST 33259-2015 Type 01 Char.B

(mm)

DN	外径	孔距	密封面	大径	小径	内孔	厚度	h	总高	颈口高	孔径	孔数	理重
	D	D1	D2	Dm	Dn	d1	b		H	H1			
10	90	60	42	26	15	8	16	2	35	14	6	4	0.68
15	95	65	47	30	19	12	16	2	35	14	6	4	0.79
20	105	75	58	38	26	18	16	2	36	14	6	4	0.97
25	115	85	68	45	33	25	16	2	38	14	6	4	1.18
32	135	100	78	56	39	31	18	2	45	18	6	4	1.83
40	145	110	88	64	46	38	19	3	48	18	7	4	2.19
50	160	125	102	76	58	49	20	3	48	18	8	4	2.78
65	180	145	122	96	77	66	22	3	53	18	10	8	3.71
80	195	160	133	110	90	78	22	3	55	18	12	8	4.44
100	230	190	158	132	110	96	24	3	61	22	12	8	6.51
125	270	220	184	160	135	121	26	3	68	26	12	8	9.41
150	300	250	212	186	161	146	28	3	71	26	12	8	12.52
200	360	310	278	245	222	202	30	3	78	26	16	12	17.44
250	425	370	335	300	278	254	32	3	78	30	18	12	24.40
300	485	430	390	352	330	303	36	4	84	30	18	16	33.29
350	550	490	450	406	382	351	40	4	89	33	20	16	46.57
400	610	550	505	464	432	398	44	4	104	33	20	16	64.81
450	660	600	555	515	484	450	46	4	104	33	20	20	72.30
500	730	660	615	570	535	500	48	4	104	39	20	20	88.91
600	840	770	720	670	636	600	54	5	120	39	20	20	123.70
700	960	875	820	766	726	690	58	5	130	45	20	24	166.81
800	1075	990	930	874	826	790	60	5	140	45	22	24	213.90
900	1185	1090	1030	980	926	892	62	5	150	52	24	28	253.00
1000	1315	1210	1140	1084	1028	992	64	5	155	56	24	28	312.00
1200	1525	1420	1350	1288	1228	1192	67	5	165	56	30	32	388.00

**PN4.0** GOST 33259-2015 Type 01 Char.B

(mm)

DN	外径	孔距	密封面	大径	小径	内孔	厚度	h	总高	颈口高	孔径	孔数	理重
	D	D1	D2	Dm	Dn	d1	b		H	H1			
10	90	60	42	26	15	8	16	2	35	6	14	4	0.68
15	95	65	47	30	19	12	16	2	35	6	14	4	0.79
20	105	75	58	38	26	18	16	2	36	6	14	4	0.97
25	115	85	68	45	33	25	16	2	38	6	14	4	1.18
32	135	100	78	56	39	31	18	2	45	6	18	4	1.83
40	145	110	88	64	46	38	19	3	48	7	18	4	2.19
50	160	125	102	76	58	48	20	3	48	8	18	4	2.81
65	180	145	122	96	77	66	22	3	53	10	18	8	3.71
80	195	160	133	112	90	78	24	3	58	12	18	8	4.80
100	230	190	158	138	110	96	26	3	68	12	22	8	7.40
125	270	220	184	160	135	120	28	3	68	12	26	8	10.00
150	300	250	212	186	161	145	30	3	71	12	26	8	13.03
200	375	320	285	250	222	200	38	3	88	16	30	12	24.44
250	445	385	345	310	278	252	42	3	101	18	33	12	37.59
300	510	450	410	368	330	301	46	4	116	18	33	16	57.10
350	570	510	465	418	382	351	52	4	120	20	33	16	70.34
400	655	585	535	480	432	398	58	4	139	20	39	16	106.76
450	680	610	560	530	484	448	60	4	139	20	39	20	107.00
500	755	670	615	580	535	495	62	4	144	20	45	20	132.33
600	890	795	735	686	636	595	63	5	145	20	52	20	180.95
700	995	900	840	790	726	695	68	5	165	20	52	24	228.25
800	1135	1030	960	908	826	795	76	5	195	22	56	24	367.40
900	1250	1140	1070	1024	926	895	79	5	220	24	56	28	437.00
1000	1360	1250	1180	1140	1028	995	82	5	240	24	56	28	541.00
1200	1575	1460	1380	1350	1228	1195	85	5	255	30	62	32	691.00



**PN6.3** GOST 33259-2015 Type 01 Char.B

(mm)

DN	外径	孔距	密封面	大径	小径	内孔	厚度	h	总高	颈口高	孔径	孔数	理重
	D	D1	D2	Dm	Dn	d1	b		H	H1			
10	100	70	50*	34	15	8	18	2	48	6	14	4	1.03
15	105	75	55*	38	19	12	18	2	48	6	14	4	1.15
20	125	90	58	48	26	18	20	2	56	8	18	4	1.80
25	135	100	68	52	33	25	22	2	58	8	18	4	2.30
32	150	110	78	64	39	31	23	2	62	8	22	4	2.94
40	165	125	88	74	46	37	24	3	68	10	22	4	3.75
50	175	135	102	86	58	47	26	3	70	10	22	4	4.63
65	200	160	132*	106	77	64	28	3	75	12	22	8	6.29
80	210	170	133	120	90	77	30	3	75	12	22	8	7.22
100	250	200	170*	140	110	94	32	3	80	12	26	8	10.71
125	295	240	205*	172	135	118	36	3	98	12	30	8	17.13
150	340	280	240*	206	161	142	38	3	108	12	33	8	24.60
200	405	345	285	264	222	198	44	3	113	16	33	12	36.60
250	470	400	345	316	278	246	48	3	118	18	33	12	50.89
300	530	460	410	370	330	294	54	4	124	18	39	16	68.15
350	595	525	465	430	382	342	60	4	144	20	39	16	106.00
400	670	585	535	480	432	386	66	4	159	20	45	16	-
450	695	610	560	534	484	436	68	4	159	28.5	45	16	151.00
500	800	705	615	594	535	485	70	4	169	20	52	20	201.00
600	925	820	735	704	636	585	76	5	185	-	56	24	283.00
700	1045	935	840	820	726	685	81	5	230	20	56	24	301.00
800	1165	1050	960	920	826	785	90	5	230	22	62	24	464.00
900	1285	1170	1070	1050	926	885	93	5	270	24	62	28	954.00
1000	1415	1290	1180	1160	1028	985	97	5	285	24	70	28	981.00
1200	1665	1530	1380	1386	1228	1185	100	5	320	30	78	32	1264.00

**PN10.0** GOST 33259-2015 Type 01 Char.B

(mm)

DN	外径	孔距	密封面	大径	小径	内孔	厚度	h	总高	颈口高	孔径	孔数	理重
	D	D1	D2	Dm	Dn	d1	b		H	H1			
10	100	70	50*	34	15	8	18	2	45	6	14	4	1.03
20	125	90	58	48	26	18	22	2	53	6	18	4	2.02
25	135	100	68	52	33	25	24	2	58	8	18	4	2.50
32	150	110	78	64	39	31	24	2	62	8	22	4	3.06
40	165	125	88	76	46	37	26	3	70	10	22	4	4.07
50	195	145	102	86	58	45	28	3	71	10	26	4	6.08
65	220	170	140*	110	77	62	32	3	83	12	26	8	8.84
80	230	180	133	124	90	75	34	3	90	12	26	8	9.98
100	265	210	175*	146	110	92	38	3	100	12	30	8	14.70
125	310	250	210*	180	135	112	42	3	115	12	33	8	23.30
150	350	290	250*	214	161	136	46	3	128	12	33	12	32.90
200	430	360	285	276	222	190	54	3	143	16	39	12	54.20
250	500	430	345	340	278	236	60	3	163	18	39	12	85.40
300	585	500	410	400	330	284	70	4	184	18	45	16	128.4
350	655	560	465	460	382	332	76	4	199	20	52	16	172.00
400	715	620	535	510	432	376	80	4	204	20	52	16	216.40
450	740	645	560	560	484	426	82	4	204	27	52	16	-



**PN16.0** GOST 33259-2015 Type 01 Char.B

(mm)

DN	外径	孔距	密封面	大径	小径	内孔	厚度	h	总高	颈口高	孔径	孔数	理重
	D	D1	D2	Dm	Dn	d1	b		H	H1			
15	105	75	47	38	19	12	20	2	52	6	14	4	1.27
20	125	90	58	48	26	18	22	2	58	8	18	4	2.08
25	135	100	68	52	33	25	24	2	58	8	18	4	2.50
32	150	110	78	64	39	31	24	2	67	8	22	4	3.07
40	165	125	88	76	46	37	28	3	75	10	22	4	4.28
50	195	145	115*	86	58	45	30	3	78	10	26	4	6.49
65	220	170	140*	110	77	62	34	3	88	12	26	8	9.38
80	230	180	150*	124	90	75	36	3	93	12	26	8	10.50
100	265	210	175*	146	110	92	40	3	103	12	30	8	15.40
125	310	250	210*	180	135	112	44	3	118	14	33	8	24.90
150	350	290	250*	214	161	136	50	3	133	14	33	12	35.00
200	430	360	315*	276	222	190	60	3	148	16	39	12	60.10
250	500	430	380*	340	278	236	68	3	168	18	39	12	94.40
300	585	500	410	400	330	284	78	4	189	18	45	16	141.00
350	655	560	465	460	382	332	84	4	204	22,5	52	16	-
400	715	620	535	510	432	376	88	4	209	23,5	52	16	-

**PN20.0** GOST 33259-2015 Type 01 Char.B

(mm)

DN	外径	孔距	密封面	大径	小径	内孔	厚度	h	总高	颈口高	孔径	孔数	理重
	D	D1	D2	Dm	Dn	d1	b		H	H1			
15	120	82	55*	40	23	14	26	2	54	6	22	4	2.11
20	130	90	58	46	29	19	28	2	57	8	22	4	2.54
25	150	102	68	54	36	25	30	2	62	8	26	4	3.59
32	160	115	78	64	43	31	32	2	67	8	26	4	4.43
40	170	124	91*	74	49	36	34	3	75	10	26	4	5.46
50	210	160	129*	105	61	46	40	3	98	10	26	8	11.30
65	260	203	167*	138	90	68	48	3	121	12	30	8	19.20
80	290	230	190*	162	110	80	54	3	135	12	33	8	27.50
100	360	292	245*	208	135	102	66	3	178	12	39	8	53.60
125	385	318	271*	234	170	130	76	3	178	14	39	12	73.20
150	440	360	306*	266	196	150	82	3	193	14	45	12	90.90
200	535	440	380*	340	248	192	92	3	233	16	52	12	160.00
250	670	572	345	460	330	254	110	3	303	18	56	16	318.00



# 英标法兰 BS EN1092-1

## BS FLANGE

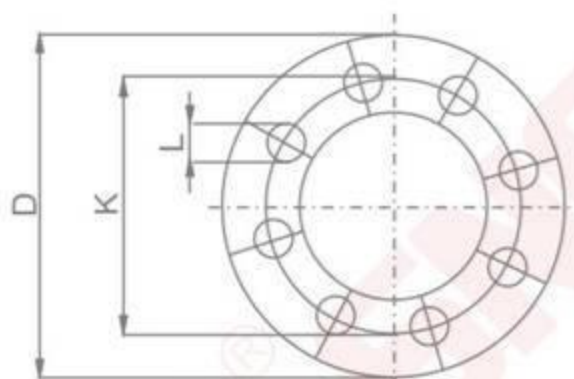

### Dimensions of PN 16 Flanges EN 1092-1

Na risbi narisano stevilo luken prikazuje le razpored le the Po delilnem krogu. Dejansko stevilo luken je razvidno iz tabele.

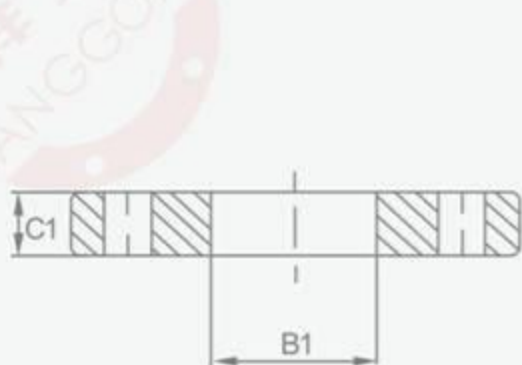

Typ 01

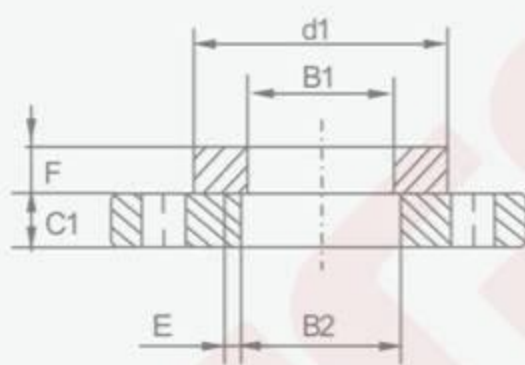

Typ 02 in 32

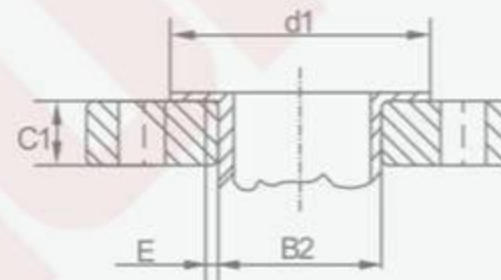

Typ 02 in 33

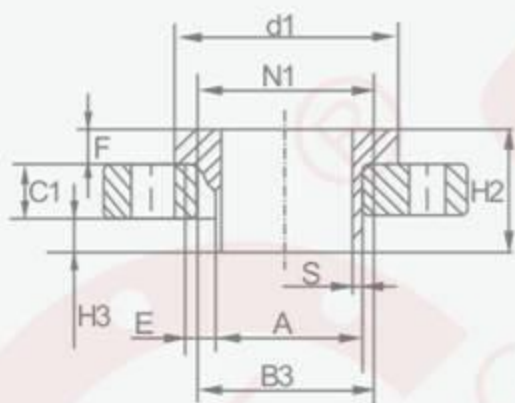

Typ 04 in 34

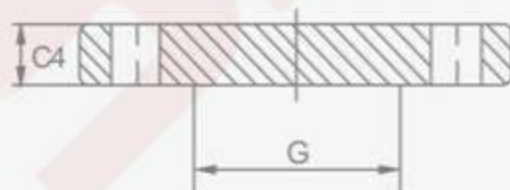

Typ 05

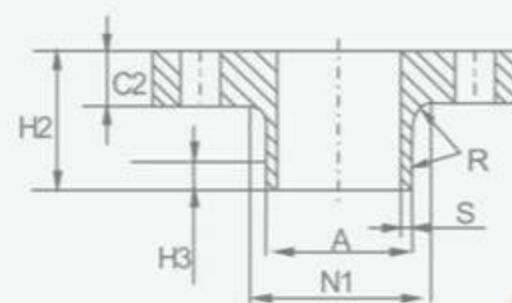

Typ 11

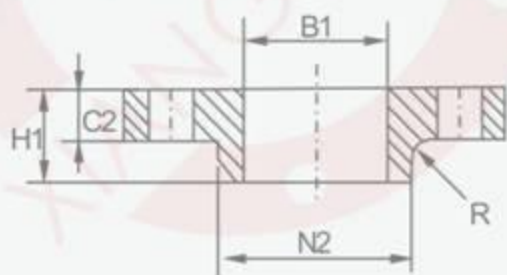

Typ 12

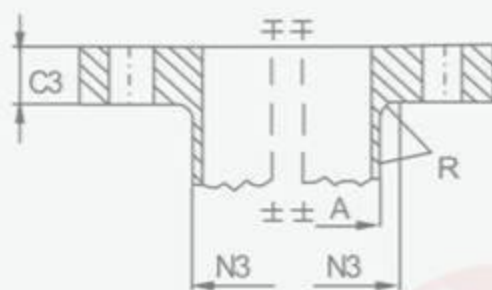

Typ 21

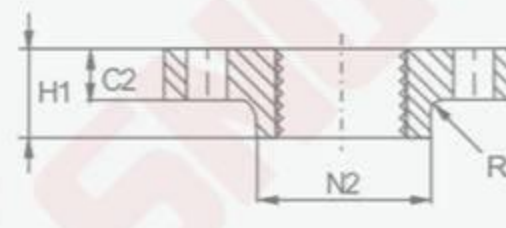

Typ 13

NOTE 1: Dimensions N1, N2 and N3 are measured at the intersection of the hub draft angle and the back face of the flange.

NOTE 2: For d1 dimensions see document "Flange facing according to EN 1092-1".



# 英标法兰 BS EN1092-1

## BS FLANGE

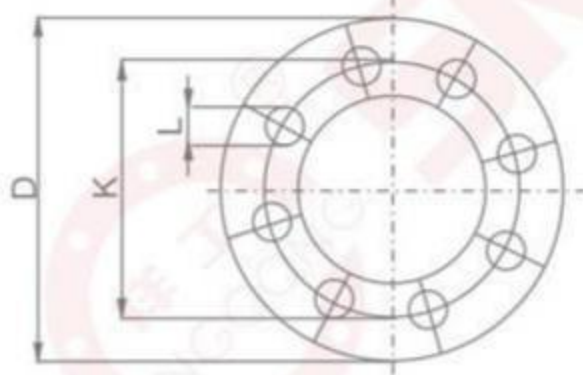

### Dimensions of PN 16 Flanges EN 1092-1

Na risbi narisano stevilo luken prikazuje le razpored le the Po delilnem krogu. Dejansko stevilo luken je razvidno iz tabele.

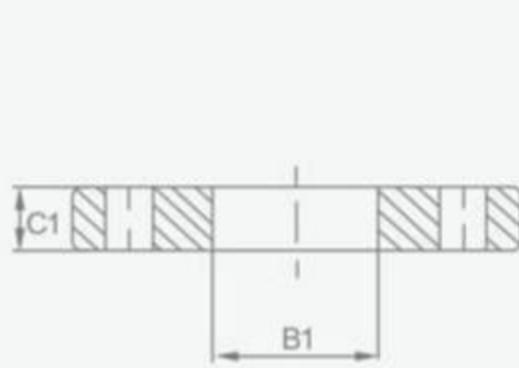

Typ 01

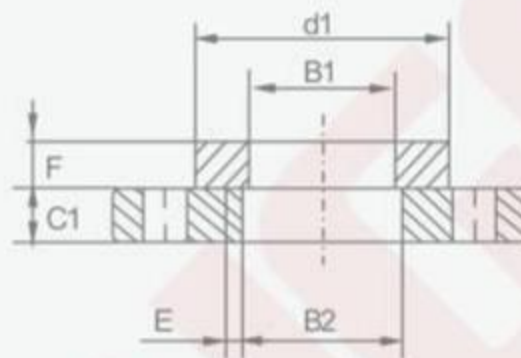

Typ 02 in 32

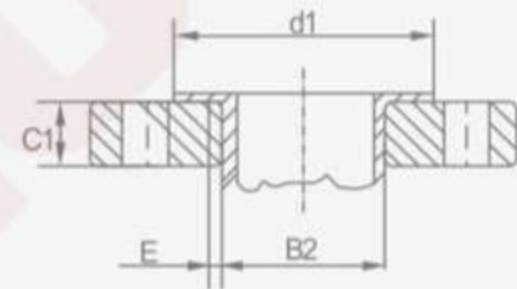

Typ 02 in 33

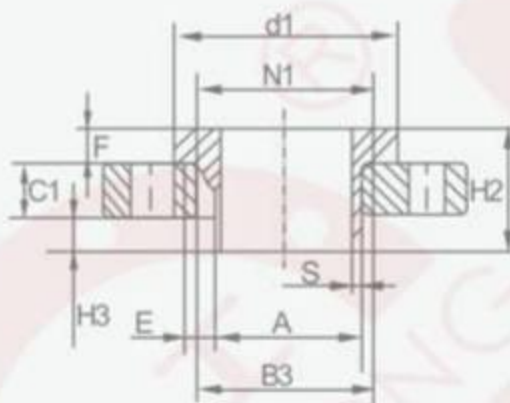

Typ 04 in 34

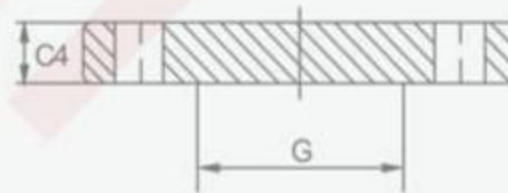

Typ 05

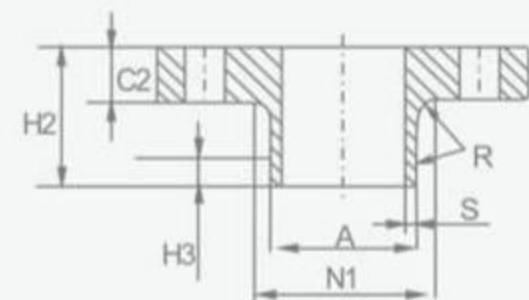

Typ 11

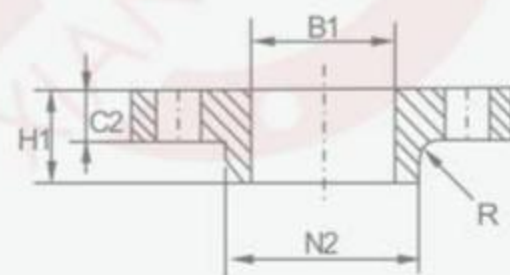

Typ 12

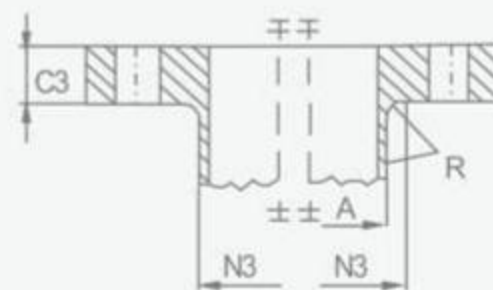

Typ 21

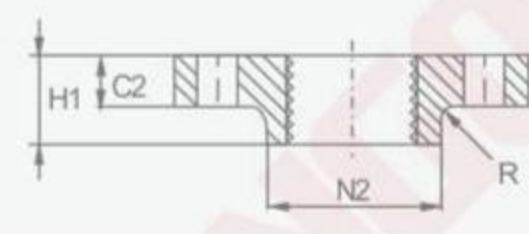

Typ 13

NOTE 1: Dimensions N1, N2 and N3 are measured at the intersection of the hub draft angle and the back face of the flange.

NOTE 2: For d1 dimensions see document "Flange facing according to EN 1092-1".



# 英标法兰 BS EN1092-1

## BS FLANGE

### PN16

(mm)

Nominal diameter DN	Mating Dimensions					Outside Diameter Of Neck	Bore Diameters				Flange Thickness				Chamfer	Collar Thickness	Diameter Of Shoulders	Length			Neck Diameters			Corner Radius	Neck Thickness (preferred Value)				
	Outside Diameter	Diameter Of Bolt Circle	Diameter Of Bolt Hole	Bolting			B1	B2	B3	C1	C2	C3	C4	E				F	G max.	H1	H2	H3	N1			N2	N3	R	S
				No	Size																								
	D	K	L	No	Size		A	B1	B2	B3	C1	C2	C3	C4				E	F	G max.	H1	H2	H3			N1	N2	N3	R
Flange Type																													
01,02,05,11,12,21					11 21 34	01 12 32	02	04	01 02 04	11 12 13	21	05	02 04	32 34	05	12 13	11 34	11 34	11 34	12 13	21	11 12 13 21	11 34						
10	90	60	14	4	M12	17.2	18.0	21	31	14	16	16	16	3	12	-	22	35	6	28	30	28	4	1.8					
15	95	65	14	4	M12	21.3	22.0	25	35	14	16	16	16	3	12	-	22	38	6	32	35	32	4	2.0					
20	105	75	14	4	M12	26.9	27.5	31	42	16	18	18	18	4	14	-	26	40	6	40	45	40	4	2.3					
25	115	85	14	4	M12	33.7	34.5	38	49	16	18	18	18	4	14	-	28	40	6	46	52	52	4	2.6					
32	140	100	18	4	M16	42.4	43.5	47	59	18	18	18	18	5	14	-	30	42	6	56	60	60	6	2.6					
40	150	110	18	4	M16	48.3	49.5	53	67	18	18	18	18	5	14	-	32	45	7	64	70	70	6	2.6					
50	165	125	18	4	M16	60.3	61.5	65	77	19	18	18	18	5	16	-	28	45	8	74	84	84	5	2.9					
65	185	145	18	**	M16	76.1	77.5	81	96	20	18	18	18	6	16	55	32	45	10	92	104	104	6	2.9					
80	200	160	18	8	M16	88.9	90.5	94	108	20	20	20	20	6	16	70	34	50	10	105	118	120	6	3.2					
100	220	180	18	8	M16	114.3	116.0	120	134	22	20	20	20	6	18	90	40	52	12	131	140	140	8	3.6					
125	250	210	18	8	M16	139.7	141.5	145	162	22	22	22	22	6	18	115	44	55	12	156	168	170	8	4.0					
150	285	240	22	8	M20	168.3	170.5	174	188	24	22	22	22	6	20	140	44	55	12	184	195	190	10	4.5					
200	340	295	22	12	M20	219.1	221.5	226	240	26	24	24	24	6	20	190	44	62	16	235	246	246	10	5.9					
250	405	355	26	12	M24	273.0	276.5	281	294	29	26	26	26	8	22	235	46	70	16	292	298	296	12	6.3					
300	460	410	26	12	M24	323.9	327.5	333	348	32	28	28	28	8	24	285	46	78	16	344	350	350	12	7.1					
350	520	470	26	16	M24	355.6	359.0	365	400	35	30	30	30	8	26	330	57	82	16	390	400	410	12	8.0					
400	580	525	30	16	M27	406.4	411.0	416	454	38	32	32	32	8	28	380	63	85	16	445	456	458	12	8.0					
450	640	585	30	20	M27	457.0	462.0	467	500	42	40	40	40	8	30	425	68	87	16	490	502	516	12	8.0					
500	715	650	33	20	M30	508.0	513.5	510	556	46	44	44	44	8	32	475	73	90	16	548	559	576	12	8.0					
600	840	770	36	20	M33	610.0	616.5	622	660	52	54	54	54	8	32	575	83	95	18	652	658	690	12	8.8					
700	910	840	36	24	M33	711.0	-	-	-	-	36	42	48	-	-	670	83	100	18	755	760	760	12	8.8					
800	1025	950	39	24	M36	813.0	-	-	-	-	38	42	52	-	-	770	90	105	20	855	864	862	12	10.0					
900	1125	1050	39	28	M36	914.0	-	-	-	-	40	44	58	-	-	860	94	110	20	955	968	962	12	10.0					
1000	1255	1170	42	28	M39	1016.0	-	-	-	-	42	46	64	-	-	960	100	120	22	1058	1072	1076	16	10.0					
1200	1485	1390	48	32	M45	1219.0	-	-	-	-	48	52	76	-	-	1160	-	130	30	1262	-	1282	16	12.5					
1400	1685	1590	48	36	M45	1422.0	-	-	-	-	52	58	-	-	-	1346	-	145	30	1465	-	1482	16	14.2					
1600	1930	1820	56	40	M52	1626.0	-	-	-	-	58	64	-	-	-	1546	-	160	35	1668	-	1696	16	16.0					
1800	2130	2020	56	44	M52	1829.0	-	-	-	-	62	68	-	-	-	1746	-	170	35	1870	-	1896	16	17.5					
2000	2345	2230	62	48	M56	2032.0	-	-	-	-	66	70	-	-	-	1950	-	180	40	2072	-	2100	16	20.0					



# 日标法兰 JIS B2220-2012

## JIS FLANGE

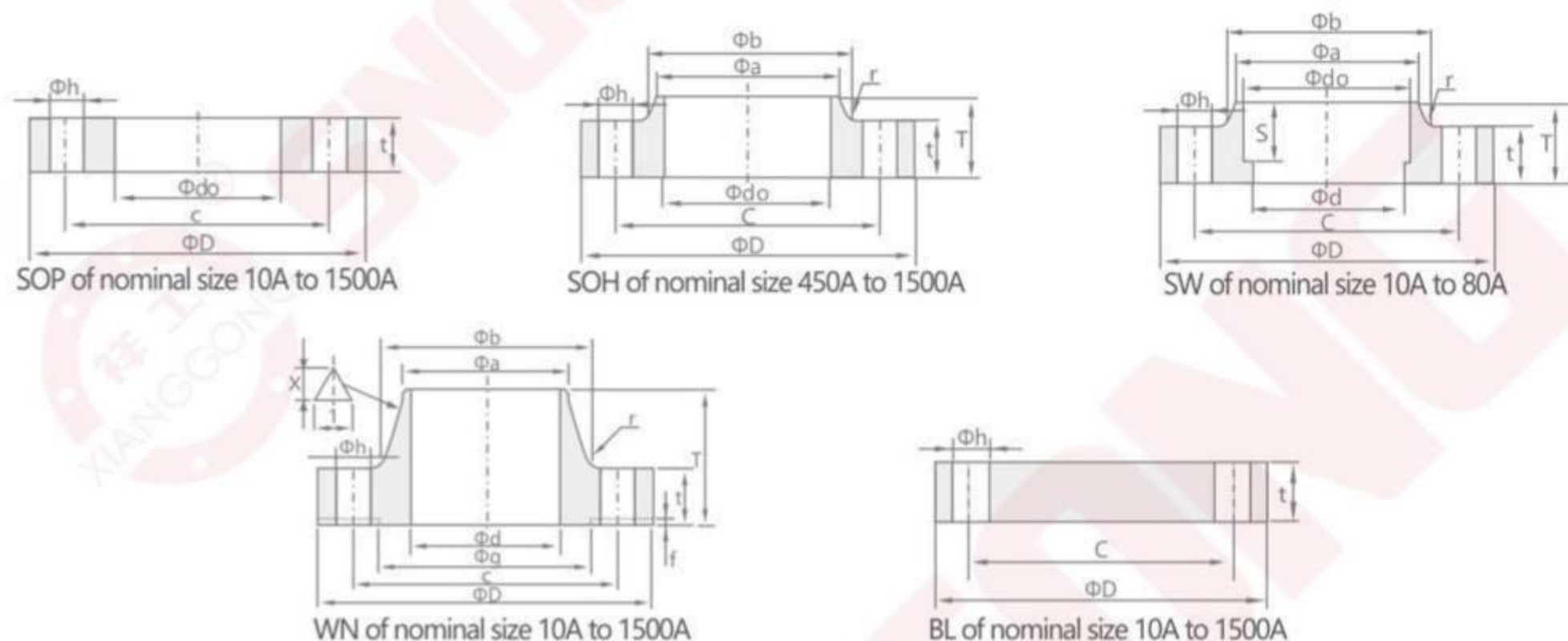

5K

(mm)

口径	法兰 外径	法兰内径		法兰厚度		法兰高度		颈小端		颈大端		深度	密封面		连接尺寸		
		SOP SOH,SW	SW,WN	Except for BL	BL	SOH SW	WN	SOH SW	WN	SOH SW	WN		SW	高度	直径	孔中距	数量
A	D	do	d	t	t	T	T	a	a	b	b	S	f	g	c	n	h
10	75	17.8	12.7	9	9	13	24	23	17.3	26	26	10	1	39	55	4	12
15	80	22.2	16.1	9	9	13	25	27	21.7	30	31	10	1	44	60	4	12
20	85	27.7	21.6	10	10	15	28	33	27.2	36	38	13	1	49	65	4	12
25	95	34.5	27.6	10	10	17	30	41	34.0	44	46	13	1	59	75	4	12
32	115	43.2	35.7	12	12	19	33	50	42.7	53	55	13	2	70	90	4	15
40	120	49.1	41.6	12	12	20	34	56	48.6	60	62	13	2	75	95	4	15
50	130	61.1	52.9	14	14	24	36	69	60.5	73	73	16	2	85	105	4	15
65	155	77.1	67.9	14	14	27	39	86	76.3	91	91	16	2	110	130	4	15
80	180	90.0	80.7	14	14	30	41	99	89.1	105	105	16	2	121	145	4	19
90	190	102.6	93.2	14	14	-	41	-	101.6	-	117	-	2	131	155	4	19
100	200	115.4	105.3	16	16	36	41	127	114.3	130	128	-	2	141	165	8	19
125	235	141.2	130.8	16	16	40	43	154	139.8	161	156	-	2	176	200	8	19
150	265	166.6	155.2	18	18	40	49	182	165.2	189	184	-	2	206	230	8	19
175	300	192.1	180.1	18	18	-	49	-	190.7	-	209	-	2	232	260	8	23
200	320	218.0	204.7	20	20	-	53	-	216.3	-	235	-	2	252	280	8	23
225	345	243.7	229.4	20	20	-	54	-	241.8	-	261	-	2	277	305	12	23
250	385	269.5	254.2	22	22	-	61	-	267.4	-	290	-	2	317	345	12	23
300	430	321.0	304.7	22	22	-	62	-	318.5	-	342	-	3	360	390	12	23
350	480	358.1	339.8	24	24	-	73	-	355.6	-	385	-	3	403	435	12	25
400	540	409.0	390.6	24	24	-	76	-	406.4	-	438	-	3	463	495	16	25
450	605	460.0	441.4	24	24	40	79	495	457.2	500	491	-	3	523	555	16	25
500	655	511.0	492.2	24	24	40	79	546	508.0	552	541	-	3	573	605	20	25
550	720	562.0	543.0	26	26	42	81	597	558.8	603	593	-	3	630	665	20	27
600	770	613.0	593.8	26	26	44	81	648	609.6	654	643	-	3	680	715	20	27
650	825	664.0	644.6	26	28	48	85	702	660.4	708	698	-	3	735	770	24	27
700	875	715.0	695.4	26	30	48	94	751	711.2	758	748	-	3	785	820	24	27
750	945	766.0	746.2	28	32	52	100	802	762.0	810	802	-	3	840	880	24	33
800	995	817.0	797.0	28	34	52	100	854	812.8	862	852	-	3	890	930	24	33
850	1045	868.0	847.8	28	36	54	108	904	863.6	912	902	-	3	940	980	24	33
900	1095	919.0	898.6	30	36	56	108	956	914.4	964	952	-	3	990	1030	24	33
1000	1195	1021.0	1000.2	32	40	60	116	1058	1016.0	1066	1052	-	3	1090	1130	28	33
1100	1305	1122.0	1098.6	32	44	71	136	1158	1117.6	1170	1162	-	3	1200	1240	28	33
1200	1420	1224.0	1200.2	34	48	77	155	1260	1219.2	1272	1272	-	3	1305	1350	32	33
1350	1575	1376.0	1346.2	34	54	80	164	1414	1371.6	1426	1472	-	3	1460	1505	32	33
1500	1730	1529.0	1498.6	36	58	86	172	1568	1524.0	1580	1582	-	3	1615	1660	36	33

备注: (1) 法兰的端面应符合 JIS B2202-2004 (2) 根据连接钢管的内径进行调整 (3) 带法兰, 此尺寸供参考 (4) 此值可四舍五入, 尺寸c为半径 (5) 该尺寸可根据有关各方之间的协议来确定



# 日标法兰 JIS B2220-2012

## JIS FLANGE

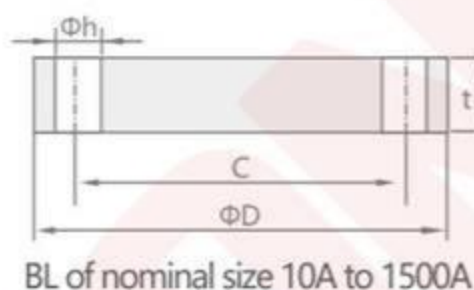
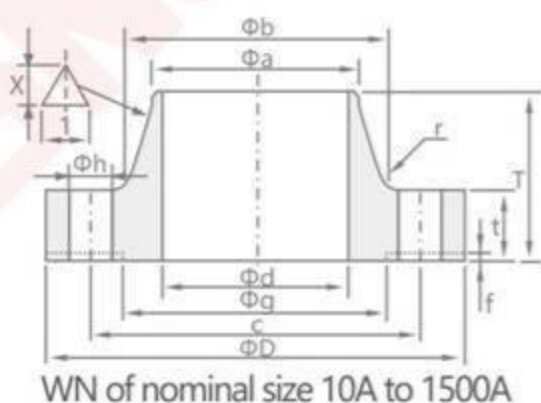
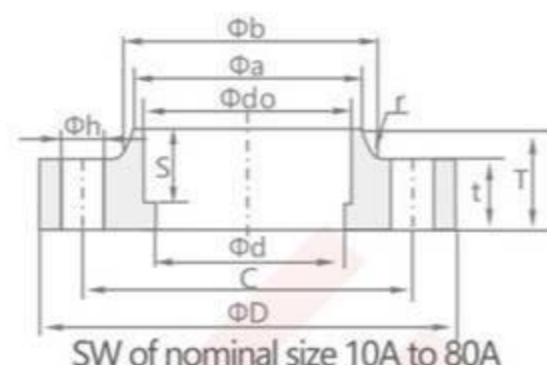
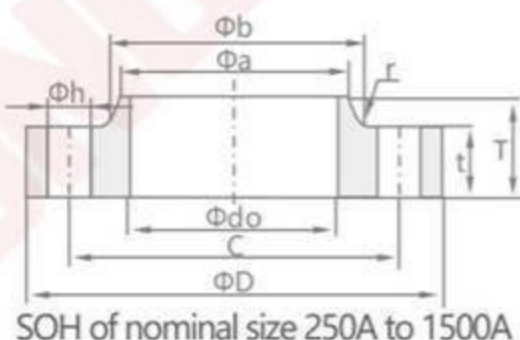
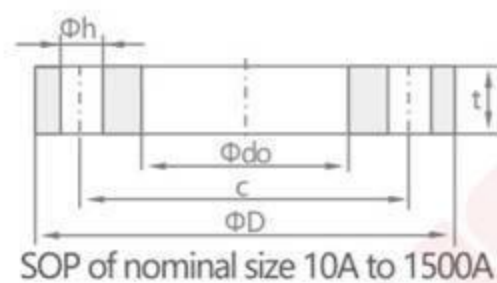

10K

(mm)

口径	法兰 外径	法兰内径		法兰厚度		法兰高度		颈小端		颈大端		深度	密封面		连接尺寸		
		SOP SOH,SW	SW,WN	Except for BL	BL	SOH SW	WN	SOH SW	WN	SOH SW	WN		SW	高度	直径	孔中距	数量
A	D	do	d	t	t	T	T	a	a	b	b	S	f	g	c	n	h
10	90	17.8	12.7	12	12	16	29	23	17.3	26	28	10	1	46	65	4	15
15	95	22.2	16.1	12	12	16	31	27	21.7	30	33	10	1	51	70	4	15
20	100	27.7	21.6	14	14	20	32	33	27.2	36	38	13	1	56	75	4	15
25	125	34.5	27.6	14	14	20	36	41	34.0	44	47	13	1	67	90	4	19
32	135	43.2	35.7	16	16	22	38	50	42.7	53	56	13	2	76	100	4	19
40	140	49.1	41.6	16	16	24	38	56	48.6	60	62	13	2	81	105	4	19
50	155	61.1	52.9	16	16	24	40	69	60.5	73	75	16	2	96	120	4	19
65	175	77.1	67.9	18	18	27	44	86	76.3	91	92	16	2	116	140	4	19
80	185	90.0	80.7	18	18	30	45	99	89.1	105	105	16	2	126	150	8	19
90	195	102.6	93.2	18	18	-	45	-	101.6	-	117	-	2	136	160	8	19
100	210	115.4	105.3	18	18	36	45	127	114.3	130	130	-	2	151	175	8	19
125	250	141.2	130.8	20	20	40	47	154	139.8	161	156	-	2	182	210	8	23
150	280	166.6	155.2	22	22	40	53	182	165.2	189	184	-	2	212	240	8	23
175	305	192.1	180.1	22	22	-	55	-	190.7	-	210	-	2	237	265	12	23
200	330	218.0	204.7	22	22	-	58	-	216.3	-	238	-	2	262	290	12	23
225	350	243.7	229.4	22	22	-	58	-	241.8	-	261	-	2	282	310	12	23
250	400	269.5	254.2	24	24	36	65	288	267.4	292	292	-	2	324	355	12	25
300	445	321.0	304.7	24	24	38	68	340	318.5	346	345	-	3	368	400	16	25
350	490	358.1	339.8	26	26	42	79	380	355.6	386	388	-	3	413	445	16	25
400	560	409.0	390.6	28	28	44	85	436	406.4	442	442	-	3	475	510	16	27
450	620	460.0	441.4	30	30	48	90	496	457.2	502	495	-	3	530	565	20	27
500	675	511.0	492.2	30	30	48	99	548	508.0	554	546	-	3	585	620	20	27
550	745	562.0	543.0	32	34	52	111	604	558.8	610	597	-	3	640	680	20	33
600	795	613.0	593.8	32	36	52	112	656	609.6	662	648	-	3	690	730	24	33
650	845	664.0	644.6	34	38	56	116	706	660.4	712	700	-	3	740	780	24	33
700	905	715.0	695.4	34	40	58	132	762	711.2	770	754	-	3	800	840	24	33
750	970	766.0	746.2	36	44	62	139	816	762.0	824	807	-	3	855	900	24	33
800	1020	817.0	797.0	36	46	64	139	868	812.8	876	858	-	3	905	950	28	33
850	1070	868.0	847.8	36	48	66	139	920	863.6	928	908	-	3	955	1000	28	33
900	1120	919.0	898.6	38	50	70	140	971	914.4	979	959	-	3	1005	1050	28	33
1000	1235	1021.0	1000.2	40	56	74	151	1073	1016.0	1081	1065	-	3	1110	1160	28	39
1100	1345	1122.0	1098.6	42	62	95	170	1175	1117.6	1185	1174	-	3	1220	1270	28	39
1200	1465	1224.0	1200.2	44	66	101	182	1278	1219.2	1290	1281	-	3	1325	1380	32	39
1350	1630	1376.0	1346.2	48	74	110	200	1432	1371.6	1450	1438	-	3	1480	1540	36	45
1500	1795	1529.0	1498.6	50	82	123	218	1585	1524.0	1605	1598	-	3	1635	1700	40	45

备注: (1) 法兰的端面应符合 JIS B2202-2004 (2) 根据连接钢管的内径进行调整 (3) 带法兰, 此尺寸仅供参考 (4) 此值可四舍五入, 尺寸c为半径 (5) 该尺寸可根据有关各方之间的协议来确定



# 日标法兰 JIS B2220-2012

## JIS FLANGE

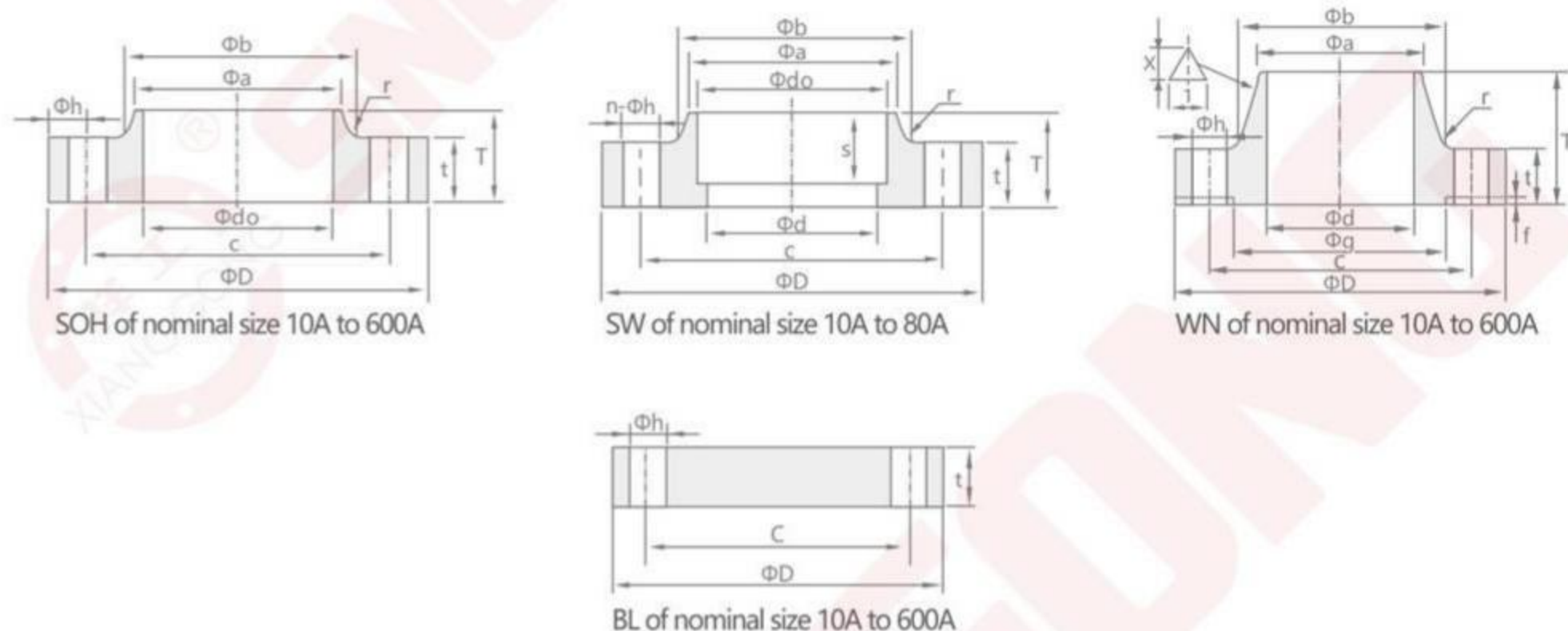

### 16K

(mm)

口径	法兰 外径	法兰内径		法兰厚度	法兰高度		颈小端		颈大端		深度	密封面		连接尺寸		
		SOP SOH,SW	SW,WN	SOH, SW, WN, BL	TR	WN	SOH,SW LJ,TR	WN,IT	SOH,SW LJ,TR	WN, IT		SW	高度	直径	孔中距	数量
A	D	do	d	t	T	T	a	a	b	b	S	f	g	c	n	h
10	90	17.8	12.7	12	16	31	26	17.3	28	29	10	1	46	65	4	15
15	95	22.2	16.1	12	16	32	30	21.7	32	34	10	1	51	70	4	15
20	100	27.7	21.4	14	20	34	38	27.2	42	39	13	1	56	75	4	15
25	125	34.5	27.2	14	20	36	46	34.0	50	47	13	1	67	90	4	19
32	135	43.2	35.5	16	22	39	56	42.7	60	56	13	2	76	100	4	19
40	140	49.1	41.2	16	24	39	62	48.6	66	62	13	2	81	105	4	19
50	155	61.1	52.7	16	24	40	76	60.5	80	75	16	2	96	120	8	19
65	175	77.1	65.9	18	27	46	94	76.3	98	92	16	2	116	140	8	19
80	200	90.0	78.1	20	30	49	108	89.1	112	105	16	2	132	160	8	23
90	210	102.6	90.2	20	-	50	120	101.6	124	118	-	2	145	170	8	23
100	225	115.4	102.3	22	36	56	134	114.3	138	134	-	2	160	185	8	23
125	270	141.2	126.6	22	40	60	164	139.8	170	162	-	2	195	225	8	25
150	305	166.6	151.0	24	40	69	196	165.2	202	192	-	2	230	260	12	25
200	350	218.0	199.9	26	-	73	244	216.3	252	244	-	2	275	305	12	25
250	430	269.5	248.8	28	-	81	304	267.4	312	298	-	2	345	380	12	27
300	480	321.0	297.9	30	-	88	354	318.5	364	352	-	3	395	430	16	27
350	540	358.1	333.4	34	-	104	398	355.6	408	398	-	3	440	480	16	33
400	605	409.0	381.0	38	-	115	446	406.4	456	452	-	3	495	540	16	33
450	675	460.0	431.8	40	-	126	504	457.2	514	510	-	3	560	605	20	33
500	730	511.0	482.6	42	-	128	558	508.0	568	561	-	3	615	660	20	33
550	795	562.0	533.4	44	-	135	612	558.8	622	616	-	3	670	720	20	39
600	845	613.0	584.2	46	-	141	666	609.6	676	670	-	3	720	770	24	39

备注: (1) 法兰的端面应符合 JIS B2202-2004 (2) 根据密封管的内径进行调整 (3) 带法兰, 此尺寸供参考 (4) 此值可四舍五入, 尺寸c为半径 (5) 该尺寸可根据有关各方之间的协议来确定



# 日标法兰 JIS B2220-2012

## JIS FLANGE

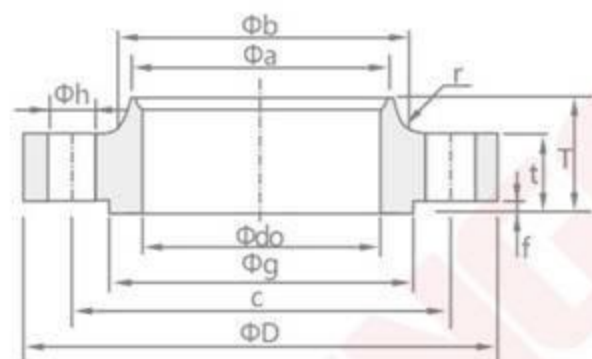

SOH Type A of nominal size 10A to 600A

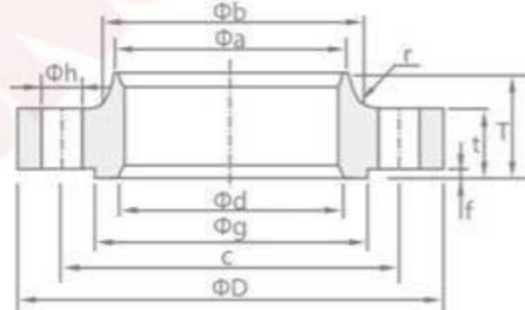

SOH Type B of nominal size 10A to 50A

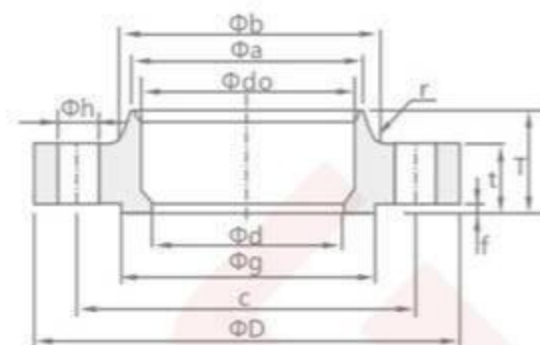

SOH Type C of nominal size 65A to 600A

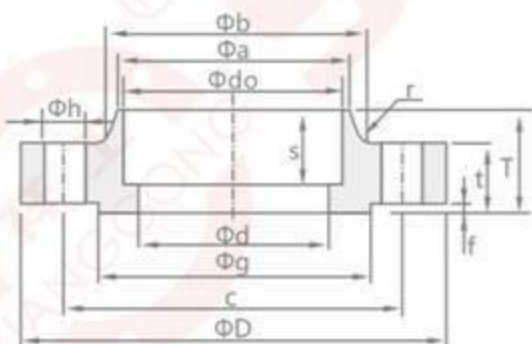

SW of nominal size 10A to 80A

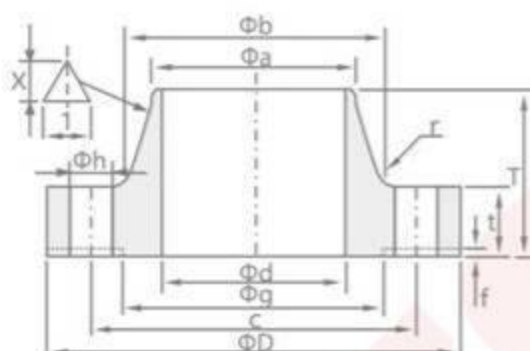

WN of nominal size 10A to 600A



BL of nominal size 10A to 600A

20K

(mm)

口径	法兰 外径	法兰内径		法兰厚度	法兰高度		颈小端		颈大端		深度	密封面		连接尺寸		
		SOH,SW	SOH SW,WN		SOH,SW,WN,BL	SOH,SW LJ,TR	WN	SOH,SW LJ,TR	WN,IT	SOH,SW LJ,TR		WN, IT	SW	高度	直径	孔中距
A	D	do	d	t	T	T	a	a	b	b	S	f	g	c	n	h
10	90	17.8	12.7	14	20	33	30	17.3	32	29	10	1	46	65	4	15
15	95	22.2	16.1	14	20	34	34	21.7	36	34	10	1	51	70	4	15
20	100	27.7	21.4	16	22	36	40	27.2	42	39	13	1	56	75	4	15
25	125	34.5	27.2	16	24	38	48	34.0	50	47	13	1	67	90	4	19
32	135	43.2	35.5	18	26	41	56	42.7	60	56	13	2	76	100	4	19
40	140	49.1	41.2	18	26	41	62	48.6	66	62	13	2	81	105	4	19
50	155	61.1	52.7	18	26	42	76	60.5	80	75	16	2	96	120	8	19
65	175	77.1	65.9	20	30	48	100	76.3	104	92	16	2	116	140	8	19
80	200	90.0	78.1	22	34	51	113	89.1	117	105	16	2	132	160	8	23
90	210	102.6	90.2	24	36	54	126	101.6	130	118	-	2	145	170	8	23
100	225	115.4	102.3	24	36	58	138	114.3	142	134	-	2	160	185	8	23
125	270	141.2	126.6	26	40	64	166	139.8	172	162	-	2	195	225	8	25
150	305	166.6	151.0	28	42	73	196	165.2	202	192	-	2	230	260	12	25
200	350	218.0	199.9	30	46	77	244	216.3	252	244	-	2	275	305	12	25
250	430	269.5	248.8	34	52	87	304	267.4	312	298	-	2	345	380	12	27
300	480	321.0	297.9	36	56	94	354	318.5	364	352	-	3	395	430	16	27
350	540	358.1	333.4	40	62	110	398	355.6	408	398	-	3	440	480	16	33
400	605	409.0	381.0	46	70	123	446	406.4	456	452	-	3	495	540	16	33
450	675	460.0	431.8	48	78	134	504	457.2	514	510	-	3	560	605	20	33
500	730	511.0	482.6	50	84	136	558	508.0	568	561	-	3	615	660	20	33
550	795	562.0	533.4	52	90	143	612	558.8	622	616	-	3	670	720	20	39
600	845	613.0	584.2	54	96	149	666	609.6	676	670	-	3	720	770	24	39

备注: (1) 法兰的端面应符合 JIS B2202-2004 (2) 根据连接钢管的内径进行调整 (3) 带法兰, 此尺寸供参考 (4) 此值可四舍五入, 尺寸c为半径 (5) 该尺寸可根据有关各方之间的协议来确定



## 日标法兰 JIS B2220-2012

### JIS FLANGE

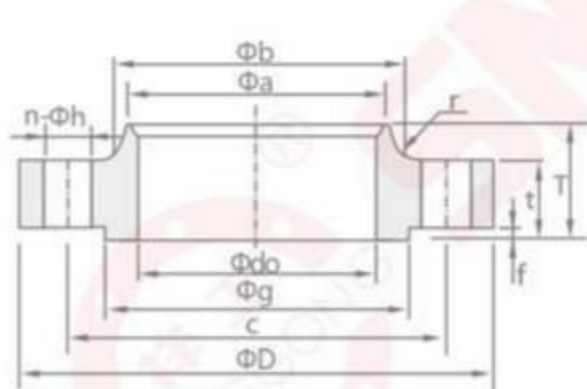

SOH of nominal size 10A to 400A

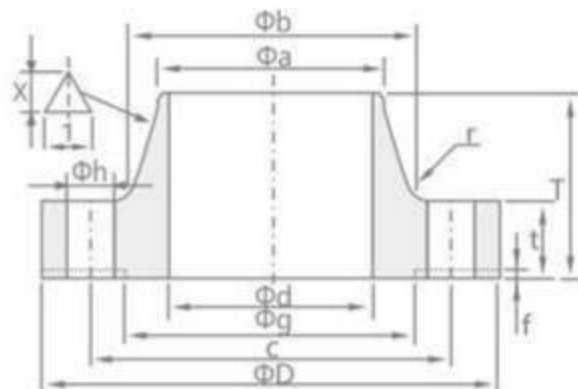

WN of nominal size 15A to 400A

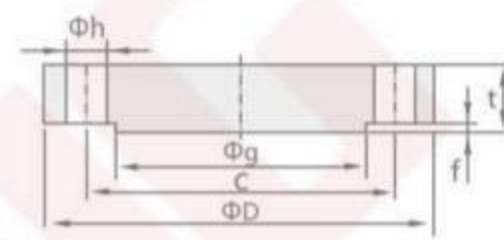

BL of nominal size 10A to 400A

## 16K

(mm)

口径	法兰 外径	法兰内径		法兰厚度	法兰高度		颈小端		颈大端		密封面		连接尺寸		
		SOH	WN	SOH,WN,BL	SOH	WN	SOH	WN	SOH	WN	高度	直径	孔中距	数量	孔径
A	D	do	d	t	T	T	a	a	b	b	f	g	c	n	h
10	110	17.8	12.7	16	24	-	30	-	34	-	1	52	75	4	19
15	115	22.2	16.1	18	26	45	36	21.7	40	40	1	55	80	4	19
20	120	27.7	21.4	18	28	45	42	27.2	46	44	1	60	85	4	19
25	130	34.5	27.2	20	30	48	50	34.0	54	52	1	70	95	4	19
32	140	43.2	35.5	22	32	52	60	42.7	64	62	2	80	105	4	19
40	160	49.1	41.2	22	34	54	66	48.6	70	70	2	90	120	4	23
50	165	61.1	52.7	22	36	57	82	60.5	86	84	2	105	130	8	19
65	200	77.1	65.9	26	40	69	102	76.3	106	104	2	130	160	8	23
80	210	90.0	78.1	28	44	73	115	89.1	121	118	2	140	170	8	23
90	230	102.6	90.2	30	46	74	128	101.6	134	130	2	150	185	8	25
100	240	115.4	102.3	32	48	76	141	114.3	147	142	2	160	195	8	25
125	275	141.2	126.6	36	54	86	166	139.8	172	172	2	195	230	8	25
150	325	166.6	151.0	38	58	95	196	165.2	204	202	2	235	275	12	27
200	370	218.0	199.9	42	64	102	248	216.3	256	254	2	280	320	12	27
250	450	269.5	248.8	48	72	118	306	267.4	314	312	2	345	390	12	33
300	515	321.0	297.9	52	78	127	360	318.5	370	366	3	405	450	16	33
350	560	358.1	333.4	54	84	134	402	355.6	412	406	3	450	495	16	33
400	630	409.0	381.0	60	92	149	456	406.4	468	462	3	510	560	16	39

备注: (1) 法兰的端面应符合 JIS B2202-2004 (2) 根据连接钢管的内径进行调整 (3) 带法兰, 此尺寸供参考 (4) 此值可四舍五入, 尺寸c为半径 (5) 该尺寸可根据有关各方之间的协议来确定



# 日标法兰 JIS B2220-2012

## JIS FLANGE

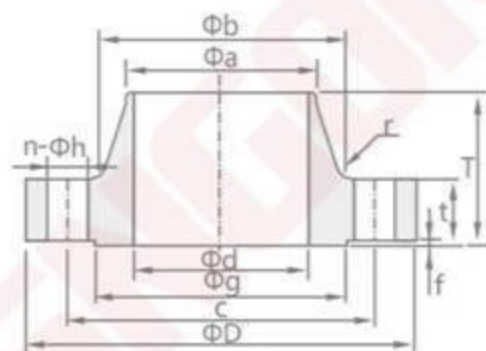

WN of nominal size 10A to 400A



BL of nominal size 10A to 400A

### 40K/63K

(mm)

口径 A	法兰 外径 D	法兰内径		法兰 厚度 t	法兰 高度 T	颈部直径		凸面		连接尺寸		
		WN d				a	b	高度 f	直径 g	孔中距 C	数量 n	孔径 h
<b>40K</b>												
15	115	15.8		20	53	21.7	40	1	55	80	4	19
20	120	21.1		20	58	27.2	45	1	60	85	4	19
25	130	26.8		22	63	34.0	54	1	70	95	4	19
32	140	35.1		24	69	42.7	62	2	80	105	4	19
40	160	40.7		24	72	48.6	72	2	90	120	4	23
50	165	52.2		26	75	60.5	88	2	105	130	8	19
65	200	65.3		30	81	76.3	108	2	130	160	8	23
80	210	76.4		32	85	89.1	119	2	140	170	8	23
90	230	89.5		34	88	101.6	130	2	150	185	8	25
100	250	101.5		36	104	114.3	146	2	165	205	8	25
125	300	-		40	-	-	-	2	200	250	8	27
150	355	150		44	120	165.2	215	2	240	295	12	33
200	405	198.7		50	135	216.3	270	2	290	345	12	33
250	475	247.5		56	154	267.4	333	2	355	410	12	33
300	540	296.4		60	159	318.5	400	3	410	470	16	39
350	585	331.8		64	168	355.6	432	3	455	515	16	39
400	645	379.1		70	181	406.4	466	3	515	570	16	39
<b>63K</b>												
15	120	15.8		23	61	21.7	42	1	55	85	4	19
20	135	21.1		25	71	27.2	46	1	60	95	4	23
25	140	26.8		27	74	34.0	56	1	70	100	4	23
32	150	35.1		30	75	42.7	60	2	80	110	4	23
40	175	40.7		32	85	48.6	75	2	90	130	4	25
50	185	52.2		34	104	60.5	92	2	105	145	8	23
65	220	65.3		38	107	76.3	118	2	130	175	8	25
80	230	76.4		40	120	89.1	130	2	140	185	8	25
90	255	89.5		42	126	101.6	140	2	150	205	8	27
100	270	101.5		44	126	114.3	154	2	165	220	8	27
125	325	-		50	-	-	-	2	200	265	8	33
150	365	150.0		54	173	165.2	230	2	240	305	12	33
200	425	198.7		60	215	216.3	280	2	290	360	12	33
250	500	247.5		68	256	267.4	348	2	355	430	12	39
300	560	296.4		77	286	318.5	402	3	410	485	16	39
350	615	331.8		81	301	355.6	438	3	455	530	16	46
400	680	379.1		89	314	406.4	490	3	515	590	16	46

备注: (1) 法兰的端面应符合 JIS B2202-2004 (2) 根据连接钢管的内径进行调整 (3) 带法兰, 此尺寸供参考 (4) 此值可四舍五入, 尺寸c为半径 (5) 该尺寸可根据有关各方之间的协议来确定



# 俄标法兰 GOST 12820-80

GOST FLANGE

PN=1.6MNA (16krc/cm<sup>2</sup>)

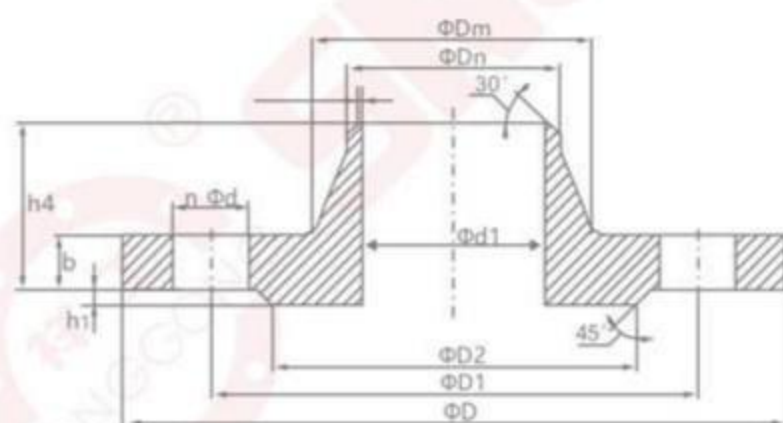

GOST 12820-80 带颈平焊法兰



GOST 12821-80 平焊法兰

口径 Dy	法兰外径 D	法兰内径 d1	密封面			孔径 d	孔中距 D1	颈小端 Dn	法兰颈 Dm	螺栓孔数量 n (个) K-BO OTB.n WT.	法兰厚度		法兰高度 h4	重量 (kg)		
			dB	D2	h						h1	b		b1	12820	12821
15	95	12	19	47	2	3	14	65	19	30	4	12	12	33	0.61	0.68
20	105	18	26	58	2	3		75	26	38		14	12	36	0.86	0.87
25	115	25	33	68	2	3		85	33	45		16	12	38	1.17	1.05
32	135	31	39	78	2	3	18	100	39	55	8	16	13	40	1.58	1.54
40	145	38	46	88	3	4		110	46	64		17	13	42	1.96	1.85
50	160	49	59	102	3	4		125	59	76		19	13	45	2.58	2.28
65	180	66	78	122	3	4	22	145	78	94	12	21	15	47	3.42	3.19
80	195	78	91	133	3	4		160	91	110		21	17	50	3.71	4.21
100	215	98	110	158	3	4		180	110	130		23	17	50	4.73	4.90
125	245	121	135	184	3	4	26	210	135	156	16	25	19	57	6.38	6.75
150	280	146	161	212	3	4		240	161	180		25	19	57	7.81	8.30
200	335	202	222	268	3	4		295	222	240		27	21	58	10.1	11.79
250	405	254	273	320	3	4	30	355	273	292	20	28	23	65	14.49	17.36
300	460	303	325	370	4	5		410	325	346		28	24	66	17.78	22.76
350	520	351	377	430	4	5		470	377	400		30	28	70	22.88	32.04
400	580	398	426	482	4	5	33	525	426	450	24	34	32	75	31	43.00
500	710	501	530	585	4	5		650	530	559		44	38	90	57.01	70.97
600	840	602	630	685	5	6		770	636	660		45	41	90	80.03	99.30
800	1020	-	820	905	5	-	39	950	820	-	28	49	-	-	104.41	-
1000	1255	-	1020	1110	5	-	45	1170	1020	-	32	58	-	-	179.37	-
1200	1485	-	1220	1330	5	-	52	1390	1220	-		71	-	-	297.78	-

(mm)



# 德标法兰 DIN FLANGE

PN=16

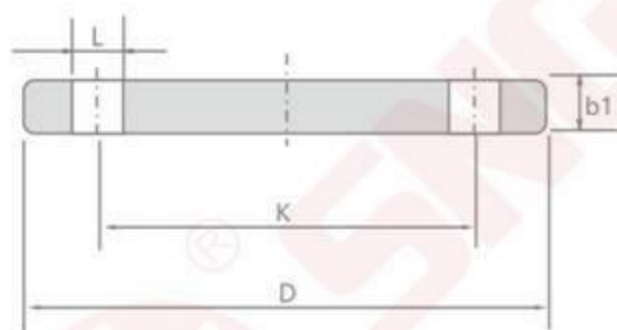

DIN 2527

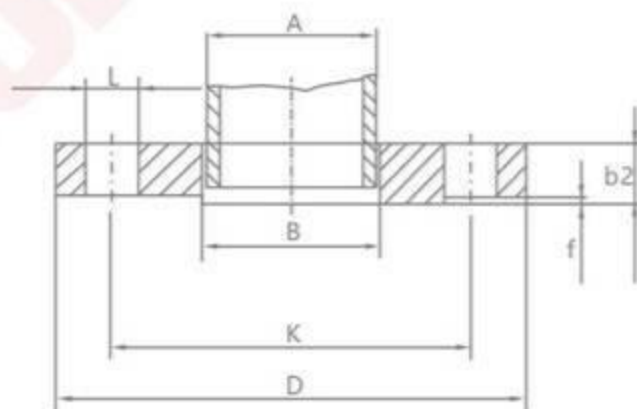

DIN 2577

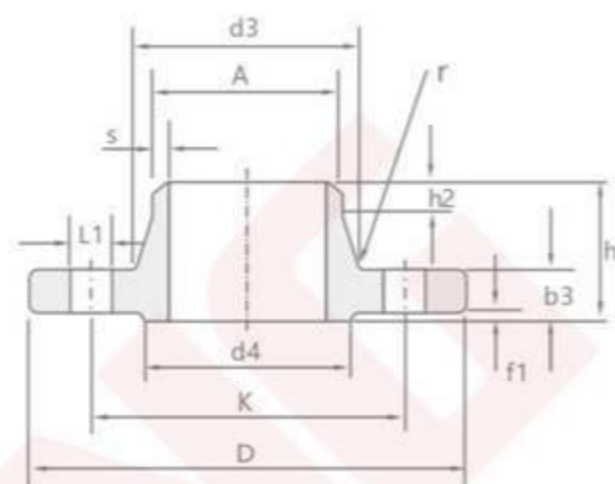

DIN 2633

(mm)

公称 通径	管子 外径	法兰 外径	螺栓孔中 心圆直径	螺栓 孔径	螺栓		密封面			法兰厚度			法兰内径 2577	法兰颈			法兰 高度	
					数量 n	螺栓 Th·	d	f	f1	b1	b2	b3	B	d3	s	r		h2
DN	A	D	K	L			d	f	f1	b1	b2	b3	B	d3	s	r	h2	h1
10	17.2	90	60	14	4	M12	41	2	2	14	14	14	18.0	28	1.8	4	6	35
15	21.3	95	65	14	4	M12	46	2	2	14	14	14	22.0	32	2.0	4	6	35
20	26.9	105	75	14	4	M12	56	2	2	16	16	16	27.5	40	2.3	4	6	38
25	33.7	115	85	14	4	M12	65	3	2	16	16	16	34.5	45	2.6	4	6	38
32	42.4	140	100	18	4	M16	76	3	2	16	18	16	43.5	56	2.6	6	6	40
40	48.3	150	110	18	4	M16	84	3	3	16	18	16	49.5	64	2.6	6	7	42
50	60.3	165	125	18	4	M16	99	3	3	18	20	18	61.5	75	2.9	6	8	45
65	76.1	185	145	18	4	M16	118	3	3	18	20	18	77.5	90	2.9	6	10	45
80	88.9	200	160	18	8	M16	132	3	3	20	20	20	90.5	105	3.2	8	10	50
100	114.3	220	180	18	8	M16	156	3	3	20	22	20	116.0	131	3.6	8	12	52
125	139.7	250	210	18	8	M16	184	3	3	22	22	22	141.5	156	4.0	8	12	55
150	168.3	285	240	22	8	M20	211	3	3	22	24	22	170.5	184	4.5	10	12	55
200	219.1	340	295	22	12	M120	266	3	3	24	26	24	221.5	235	5.9	10	16	62
250	273.0	405	355	26	12	M24	319	3	3	26	29	26	276.5	292	6.3	12	16	70
300	323.9	460	410	26	12	M24	370	4	4	28	32	28	327.5	344	7.1	12	16	78
350	355.6	520	470	26	16	M24	429	4	4	30	35	30	359.0	390	8.0	12	16	82
400	406.4	580	525	30	16	M27	480	4	4	32	38	32	411.0	445	8.0	12	16	85
450	457.0	640	585	26	20	M27	548	4	-	-	42	-	462.0	131	3.6	8	12	52
500	508.0	715	650	33	20	M30	609	4	4	36	46	34	513.5	548	8.0	12	16	90
600	610.0	840	770	36	20	M33	720	5	5	38	52	36	616.5	652	8.8	12	18	95